

Concrete Inspection Pit



GXCIP



GXCIP - N



GXCIP - H

Cover

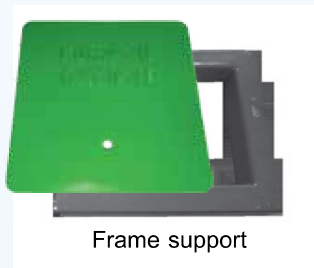

Frame support

Square Type

Code No.	Dimensions (mm)			Weight (kg)
	L	W	H	
GXCIP	320	320	190	25.7
GXCIP-N	320	320	190	21.5

Tested : IEC 62561 - 5

Application : Inspection and Testing point in grounding system
Available for high load up to 6,000 kg

Material : Concrete

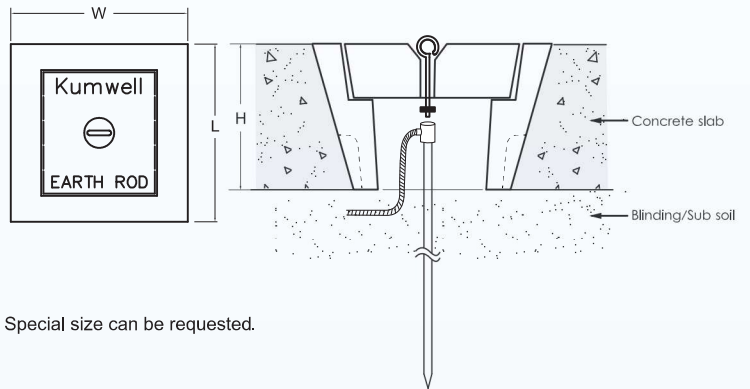

Special size can be requested.

Code No.	Dimensions (mm)			Weight (kg)
	L	W	H	
GXCIP-H	320	320	190	30.0

Tested : IEC 62561 - 5

Application : Inspection and Testing point in grounding system
Available for high load up to 15,000 kg

Material : Body - Concrete
Cover - Cast iron steel with epoxy gray color
Frame - Mild steel

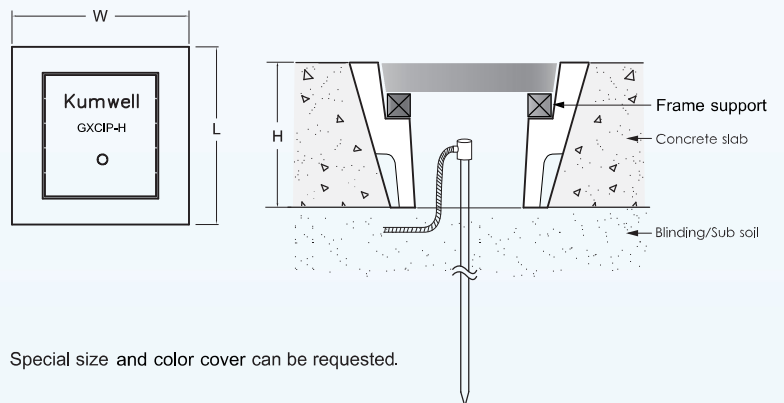

Special size and color cover can be requested.